



CHEFMATE FULL TOUCH CMFE10



Elektro-Kombidämpfer, full touch

TECHNISCHE SPEZIFIKATIONEN:

Kapazität Garraum	10
Garraumtypologie	GN 1/1 - 60x40cm
Dampfeinspritzung	direct
Electrische Leistung (kW)	18,5
Äussere Abmessungen - WxDxH (cm)	89x79,5x98

ZUSÄTZLICHE SPEZIFIKATIONEN:

Garraum Abmessungen - LxPxH (cm)	63x44x71
Schienenabstand (mm)	70
Anschluss (N)	400V 3N 50Hz
Gewicht (kg)	160

Die hohe Funktionalität und das intuitive neue Interface mit dem Full-Touch-Display, machen die Nutzung und die Programmierung des Chefmate Full-Touch äußerst schnell und bietet dem Koch so verschiedene Möglichkeiten, die tägliche Arbeit flexibler und einfacher zu gestalten.

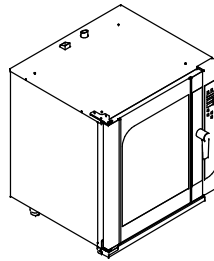
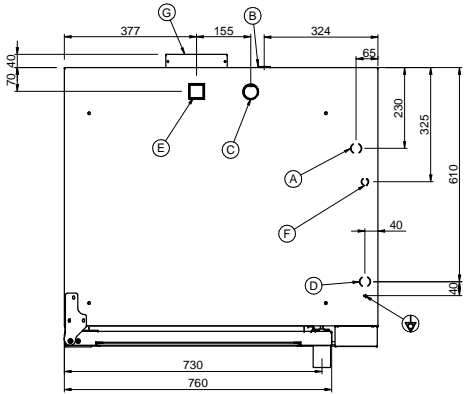
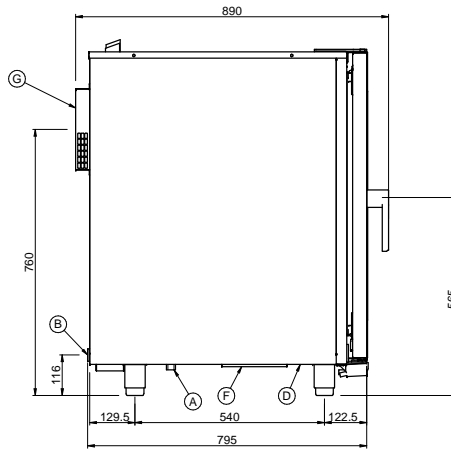
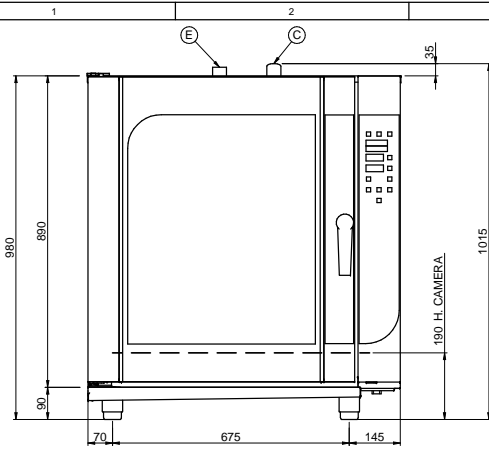

- A: INGRESSO ACQUA ADDOLCITA 3/4" G
- B: SCARICO ACQUA 1" G
- C: TUBO SFIATO (VAPORE) D 40mm
- D: INGRESSO CAVO DI ALIMENTAZIONE ELETTRICA
- E: TUBO ASPIRAZIONE ARIA
- F: INGRESSO TUBO DETERGENTE
- G: VENTOLA RAFFREDDAMENTO POSTERIORE

REV.	MODIFICATION	DATE	MODIFIED BY

MATERIAL	Thk	Formal feedstock	Dimensions are in mm	SURFACE TOLERANCES
FINISHED OR TREATMENT	Thk Treat. μ	Color		3.2 \sqrt{r}
USED FOR	NEW	Scale	Date	GENERAL TOLERANCES
FORNI CHEFMATE		1/10	14/05/14	VEDI I.C. 82
MBM BRESCELLO (RE) - ITALY	TITLE	Raw Code	Deep Drawing Code	GENERAL GEOMETRIC TOLERANCES
	SCHEMA INSTALLAZIONE CHEFMATE CME10-CMFE10-CYG10	Imploded Code	Prepared Code	ISO 2768
				Approved by
				Drawn by G. FANETTI
				Die of SCHEMA INST CM10
				Rev. -

La Ditta si riserva, a termini di legge, la proprietà di questo disegno con divieto di riprodurlo o di renderlo pubblico a Terzi senza la Sua autorizzazione.
The Company reserves the right by law, the property of this drawing with no copy or to make it public to any third party without your permission.